

# CMP Attachments, LLC.

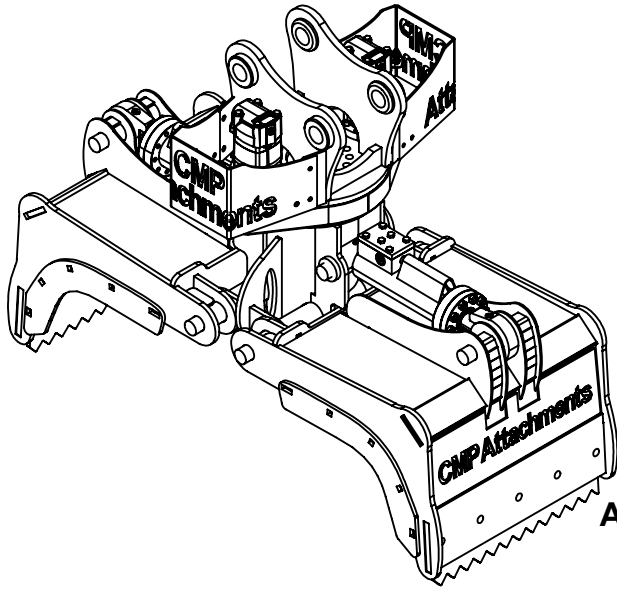

## HYDRA GRAPPLE

MODEL:	142
MAX OPEN:	54"
MIN CLOSED:	13 1/2"
VOLUME OPENED:	12 1/2 FT <sup>3</sup>
VOLUME CLOSED:	6 FT <sup>3</sup>
CYLINDER BORE:	3"
MAX PRESSURE:	4500 PSI
MAX TORQUE:	15,000 IN-LB
MACHINE WEIGHT:	11,000-14,500 LBS
APPROXIMATE WEIGHT:	895 LBS
OPTIONS:	CLOSED SIDE EDGES

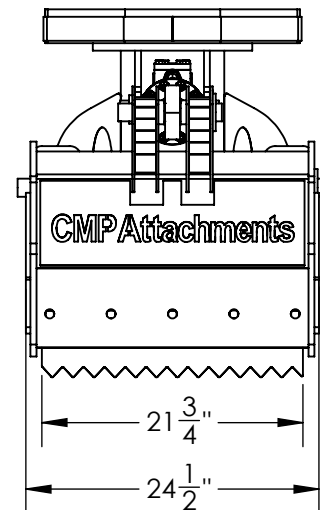
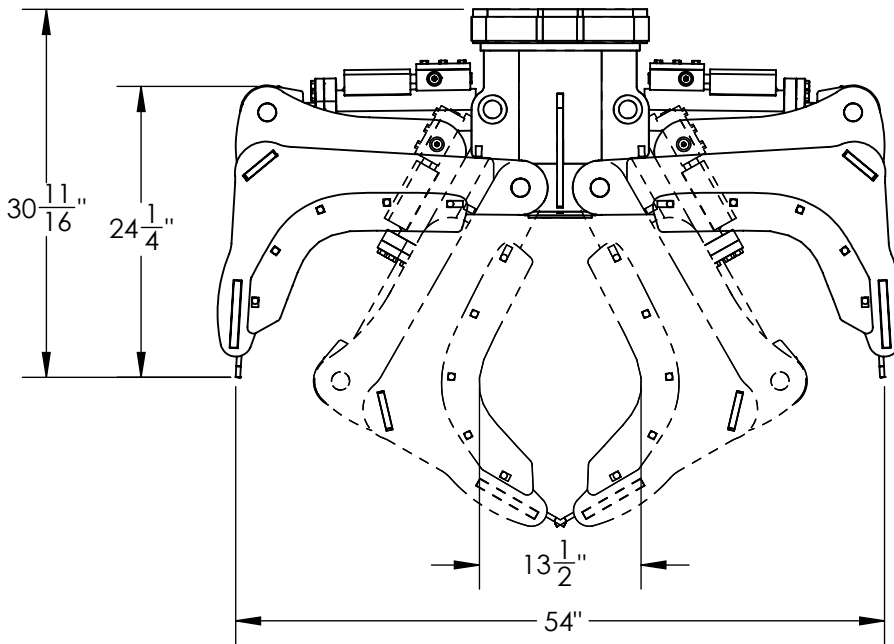

### Features

- Dual rotational drive motor provides intense rotational torque.
- Motors have built in cross reliefs which serves as a cushion when stopping rotation under load.
- Heavy duty AR-400 hardened steel with 177,000lb tensile strength and Rockwell hardness of 440.
  - High strength body made from T1 steel is three times stronger than standard steel.
- Exclusive hydraulic cylinder lock valves efficiently hold material without needing to continuously apply auxiliary hydraulic pressure.
  - Stress proof bolts are able to withstand tremendous amounts of flexing and fatigue long term.
  - Excavator tooth bar is ideal for excavating or grabbing boulders and other large objects.
- Electronic control valve option eliminates the need for expensive secondary auxiliary hydraulics on an excavator.
  - Rigid quality control during manufacturing ensures reliability.
  - Completely fabricated in our facility in Clear Lake Minnesota.